

Features

- * Identical to ISO6432 $\phi 8 \sim \phi 25$.
- * Adjustable cushion at both ends is able to absorb vibration from high speed impact and provide stable movement.
- * Built in magnet for sensor use.
- * Caps are rolled and polished, which provides stable quality.
- * Stainless steel SUS304 barrel provides stable movement and features high quality and durable life.
- * Stainless steel SUS304 barrel features corrosion resistance and strongly mechanical strength.



How to order

PC	32	B	50	C	SF	1	FA	Y
Type	Bore size	Magnet	Stroke	Cushion	Sensor type	Number of sensor	Mounting parts	Rod end joint
PC	8 $\phi 8$			Blank W/O cushion C W/1 cushion $\phi 20 \sim \phi 40$	Blank W/O sensor SF LED in front	1 pc 2 pcs	Blank W/O mounting parts FA Front flange FB Rear flange CA Male clevis CB Female clevis LB Foot mounting	Blank W/O rod end joint Y Double knuckle joint I Single knuckle joint P Eyebolt floating joint T Basic floating joint L Axial foot type floating joint F Flange type floating joint.
PCC	10 $\phi 10$							
PCD	12 $\phi 12$							
PCA	16 $\phi 16$							
PCB	20 $\phi 20$							
PCH	25 $\phi 25$							
PCG	32 $\phi 32$							
PCM	40 $\phi 40$							
PCF								
APCC								
APDC								
APC								
APD								

How to order Mounting parts / Rod end joints

ZIP	FA	FY	32
PC series	Mounting parts	Rod end joint	Bore size
	Blank W/O mounting parts FA Front flange FB Rear flange CA Male clevis CB Female clevis LB Foot mounting	Blank W/O rod end joint FY Double knuckle joint FI Single knuckle joint P Eyebolt floating joint T Basic floating joint L Axial foot type floating joint F Flange type floating joint.	8 $\phi 8$ 10 $\phi 10$ 12 $\phi 12$ 16 $\phi 16$ 20 $\phi 20$ 25 $\phi 25$ 32 $\phi 32$ 40 $\phi 40$

Specifications

Bore size	$\phi 8$	$\phi 10$	$\phi 12$	$\phi 16$	$\phi 20$	$\phi 25$	$\phi 32$	$\phi 40$
Port size	M5xP0.8				1/8"			
Fluid	Compressed air							
Acting	Double acting or single acting							
Cushion	Adjustable type							
Operating pressure range	1.5 ~ 8.5 kgf/cm ²							
Max. operating pressure	9.5 kgf/cm ²							
Barrel material	Stainless steel SUS304							
Magnet	Built-in							
Ambient temperature	-5°C ~ 60°C							
Piston speed	50~700mm/Sec							

Material of parts

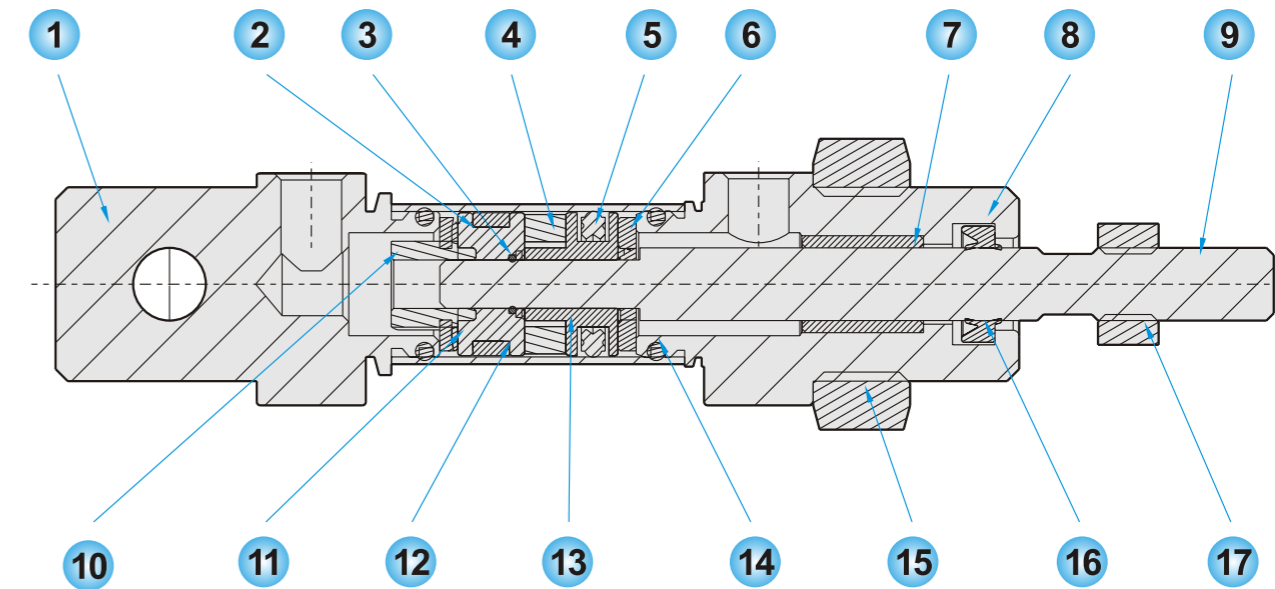

No.	Description	Material	Qty.	No.	Description	Material	Qty.
1	Rear cover	Aluminum alloy	1	10	Nut	Fe+Ni	1
2	Wear ring	Teflon +Graphite	1	11	Rear piston	Aluminum alloy	1
3	O-ring	NBR	1	12	Barrel	SUS304	1
4	Magnet	Rubber	1	13	Front piston	Aluminum alloy	1
5	U piston seal	NBR	1	14	O-ring	NBR	2
6	Bumper	NBR	2	15	Fixing nut	SS41+Ni	1
7	Bush bearing	Brass	1	16	Rod seal	NBR	1
8	Front cover	Aluminum alloy	1	17	Nut	Fe+Ni	1
9	Piston rod	S45C+Cr	1				

Stroke table

Bore size	Acting	Standard stroke (mm)
$\phi 8$	Double acting	15, 25, 50, 75, 100, 125, 150
$\phi 10$	Double acting	15, 25, 50, 75, 100, 125, 150
$\phi 12$	Double acting	15, 25, 50, 75, 100, 125, 150
$\phi 16$	Double acting	15, 25, 50, 75, 100, 125, 150
$\phi 20$	Single acting	25, 50
$\phi 20$	Double acting	25, 50, 75, 100, 125, 150, 200
$\phi 25$	Single acting	25, 50
$\phi 25$	Double acting	25, 50, 75, 100, 125, 150, 200, 250, 300
$\phi 32$	Single acting	25, 50
$\phi 32$	Double acting	25, 50, 75, 100, 125, 150, 200, 250, 300, 400, 500
$\phi 40$	Single acting	25, 50
$\phi 40$	Double acting	25, 50, 75, 100, 125, 150, 200, 250, 300, 400, 500

Note: Please contact our sales for non-standard stroke.

Theoretical force

Bore size	φ 8		φ 10		φ 12		φ 16		φ 20		φ 25		φ 32		φ 40		
	Rod diameter φ 4		φ 4		φ 6		φ 6		φ 8		φ 10		φ 12		φ 16		
Acting	Double acting		Double acting		Double acting		Double acting		Double acting		Double acting		Double acting		Double acting		
	Push	Pull	Push	Pull	Push	Pull	Push	Pull	Push	Pull	Push	Pull	Push	Pull	Push	Pull	
Operating pressure (kgf/cm ²)	1	0.5	0.38	0.79	10.5	1.13	0.9	2.01	1.81	3	2	4	3	8	8	12	10
	2	1	0.75	1.57	21	2.26	1.81	4.02	3.62	6	5	9	8	16	13	25	21
	3	1.51	1.13	2.36	31.5	3.39	2.27	6.03	5.44	9	7	14	12	24	20	37	31
	4	2.01	1.51	3.14	42	4.62	3.63	8.04	7.25	12	10	19	16	32	27	50	42
	5	2.51	1.89	3.93	52.5	5.65	4.54	10.05	9.07	15	13	24	20	40	34	62	52
	6	3.01	2.27	4.71	63	6.78	5.45	12.06	10.88	18	15	29	24	48	47	75	63
	7	3.51	2.64	5.49	73.5	7.91	6.36	14.07	12.69	21	18	34	28	56	48	87	73
	8	4.02	3.02	6.28	84	9.04	7.27	16.07	14.47	25	21	39	32	64	55	100	84
	9	4.52	3.40	7.07	94.5	10.17	8.18	18.08	16.28	28	23	44	37	72	62	113	94
	10	5.03	3.78	7.85	105	11.3	9.09	20.08	18.09	31	26	49	41	80	69	126	105

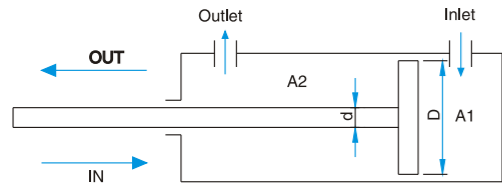

- A : Cylinder sectional area (cm²)
- D : Diameter of bore (cm)
- d : Diameter of piston (cm)
- F : Theoretical force (kg)
- P : Operating pressure (kgf/cm²)
- N : Newton
- Q : Air consumption l/min
- A1 : Head end effective piston area (cm²)
- A2 : Rod end effective piston area (cm²)
- L : Stroke (cm)
- P : Pressure (kgf/cm²)
- N : Number of strokes per minute
- K : Safety factor=2

Actual in force

$$A = \frac{\pi}{4} (D^2 - d^2) \times P - R$$

Actual out force

$$F = \frac{\pi D^2}{4} \times P - R$$

Theoretical force

$$A = \frac{\pi D^2}{4}$$

$$F = A \times P$$

$$N = F \times 9.81 \text{ N/kg}$$

Output efficiency:

The output efficiency of air cylinder is depended upon the size of piping tubes, size of control valves, cylinder internal friction, and operating speed. It is difficult in solving these factors precisely so we must put more tolerance in design.

Low speed takes 80 percent.

High speed takes less than 50 percent.

Normal operating speed takes 65 percent.

Calculate of air consumption:

The air consumption is an amount of air to be consumed in cylinder or in the inside of tubing between the cylinder and the selector valve when the selector valve operates in an equipment used with cylinder and it is required to select a compressor.

$$Q = \frac{(A1+A2)L(P+1)N}{1000} \text{ (l/min)} \times K$$

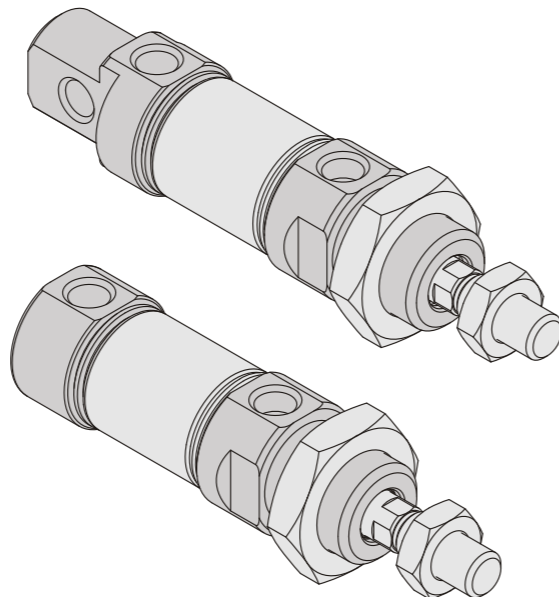

Dimensions

PCC Boss-cut type

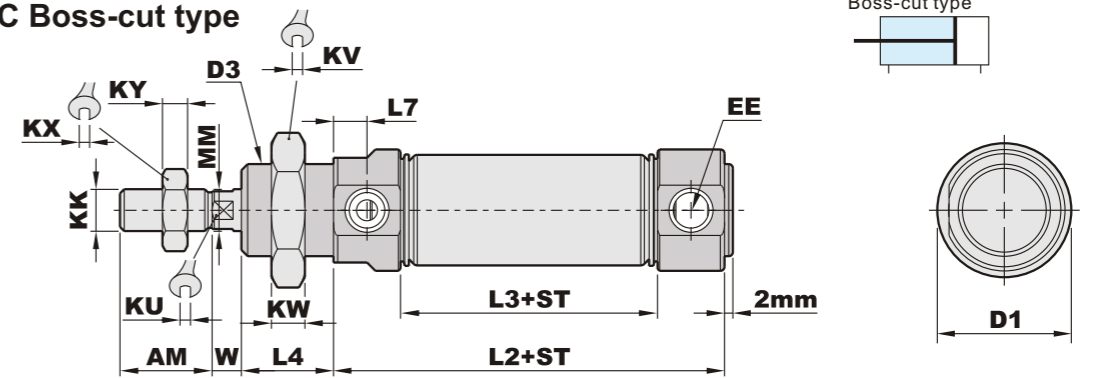

PC, PCC
ISO6432 Standard,
Boss-cut type

PC Standard integrated clevis type

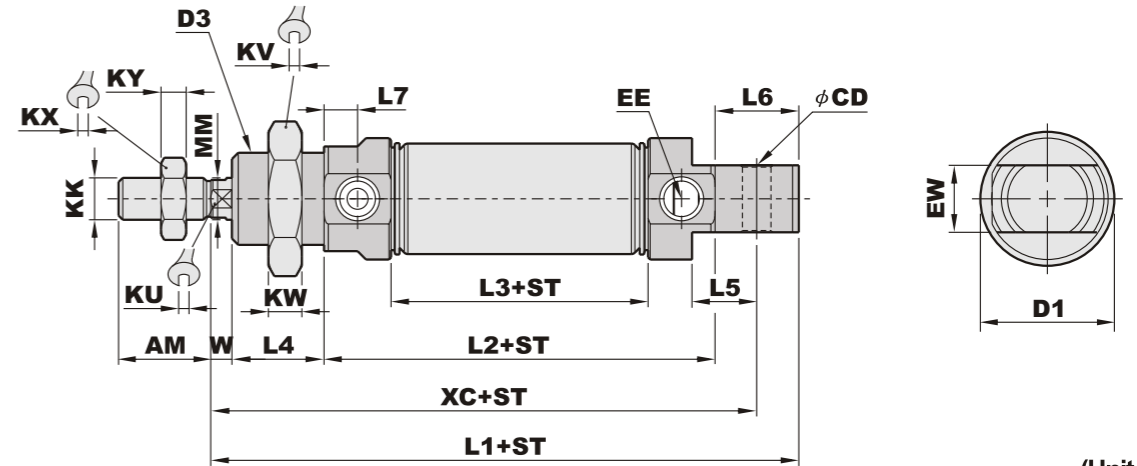

(Unit : mm)

Bore size	AM	D1	φ CD	D3	L1	L2	L3	L4	L5	L6	L7
φ 8	12	17	φ 4	M12xP1.25	71.4	43.4	25.4	12	6	13.4	4.5
φ 10	12	17	φ 4	M12xP1.25	71.4	43.4	25.4	12	6	13.4	4.5
φ 12	16	20	φ 6	M16xP1.5	84.4	45.4	27.4	17	9	18.4	4.5
φ 16	16	20	φ 6	M16xP1.5	90	51	31	17	9	17	5
φ 20	20	29	φ 8	M22xP1.5	109	69	36	18	12	18	7.75
φ 25	22	29	φ 8	M22xP1.5	117.5	69.5	37.5	20	12	20	8
φ 32	22	37	φ 10	M27xP2.0	133	83	47	20	13.5	22	9
φ 40	24	45	φ 10	M33xP2.0	138	85	49	20	13.5	22	9

Bore size	KK	KU	KV	KW	KX	KY	MM	W	EW	XC	EE
φ 8	M4xP0.7	3.4	19	6	7	3.2	φ 4	4	8	64	M5xP0.8
φ 10	M4xP0.7	3.4	19	6	7	3.2	φ 4	4	8	64	M5xP0.8
φ 12	M6xP1.0	5	24	8	10	5	φ 6	5	12	75	M5xP0.8
φ 16	M6xP1.0	5	24	8	10	5	φ 8	5	12	82	M5xP0.8
φ 20	M8xP1.25	7	32	8	13	6	φ 8	6	16	95	PS 1/8
φ 25	M10xP1.25	9	32	8	17	6	φ 10	8	16	104	PS 1/8
φ 32	M10xP1.25	10	35	9.5	17	6	φ 12	8	22	120	PS 1/8
φ 40	M12xP1.25	14	41	9.5	22	8	φ 16	11	26	125	PS 1/8

Dimensions

PCD Double rod type

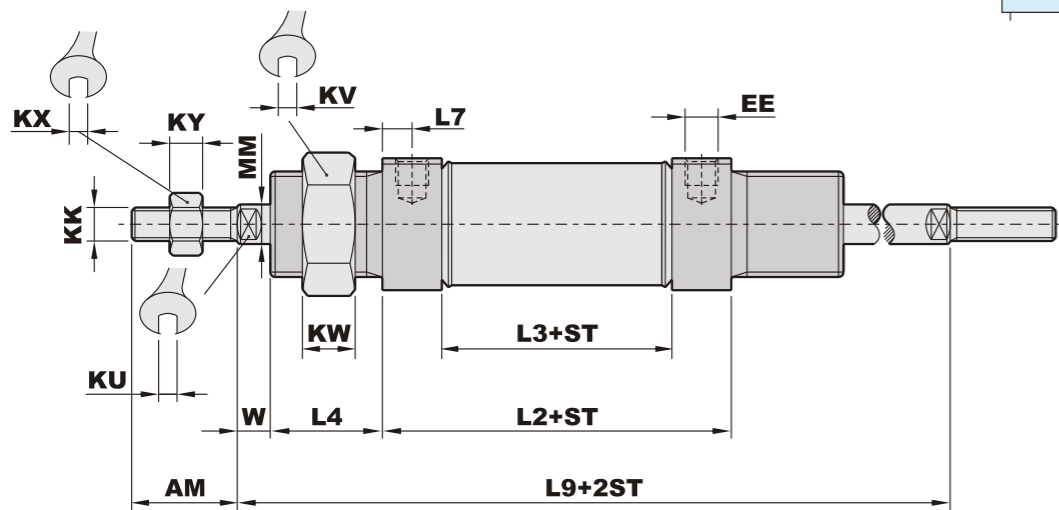
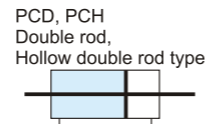

PCA Stroke adjustable 25mm PCB Stroke adjustable 50mm

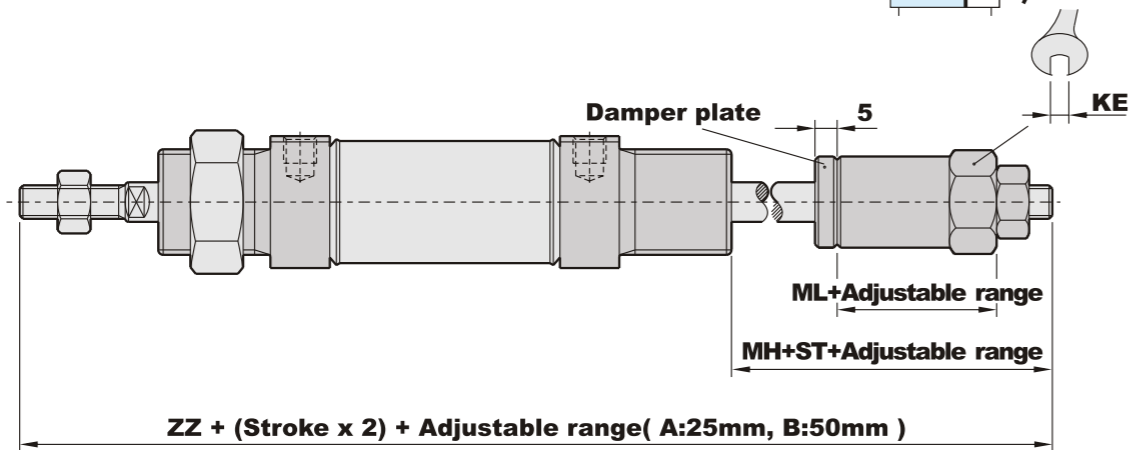
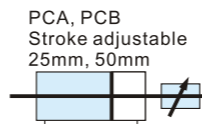

(Unit : mm)

Bore size	AM	L2	L3	L4	L7	L9	EE	KU	KV	KW	KX
φ 20	20	67	36	18	7.6	115	PS 1/8	7	32	8	13
φ 25	22	69.5	37.5	20	8	125.5	PS 1/8	9	32	8	17
φ 32	22	83	47	20	9	139	PS 1/8	10	35	9.5	17
φ 40	24	85	49	20	9	147	PS 1/8	14	41	9.5	22

Bore size	KY	MM	W	KK	ZZ	MH	ML	KE
φ 20	4	φ 8	6	M8xP1.25	160	31	20	19
φ 25	6	φ 10	8	M10xP1.25	172.5	33	20	19
φ 32	6	φ 12	8	M10xP1.25	188	35	22	21
φ 40	8	φ 16	11	M12xP1.25	195	35	22	26

Dimensions

APCC Single acting/Spring return/Boss-cut

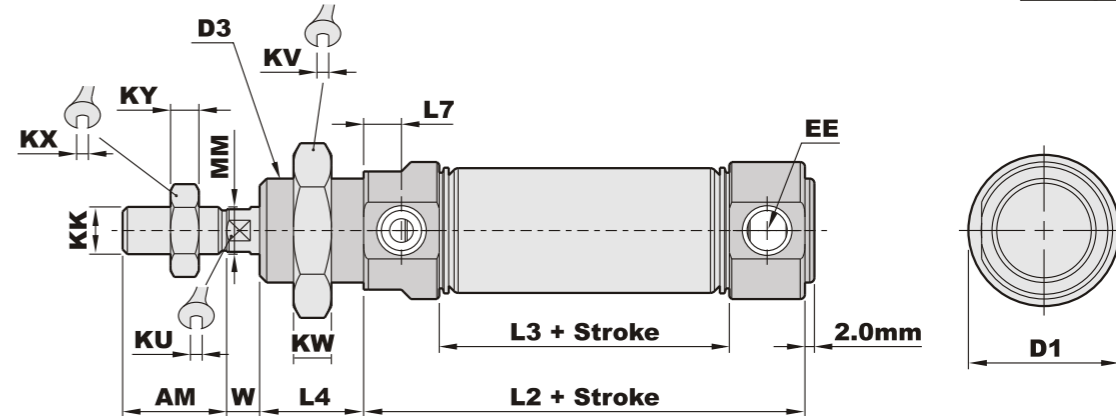
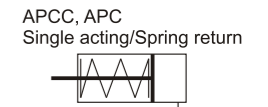

APC Single acting/Spring return/Standard integrated clevis

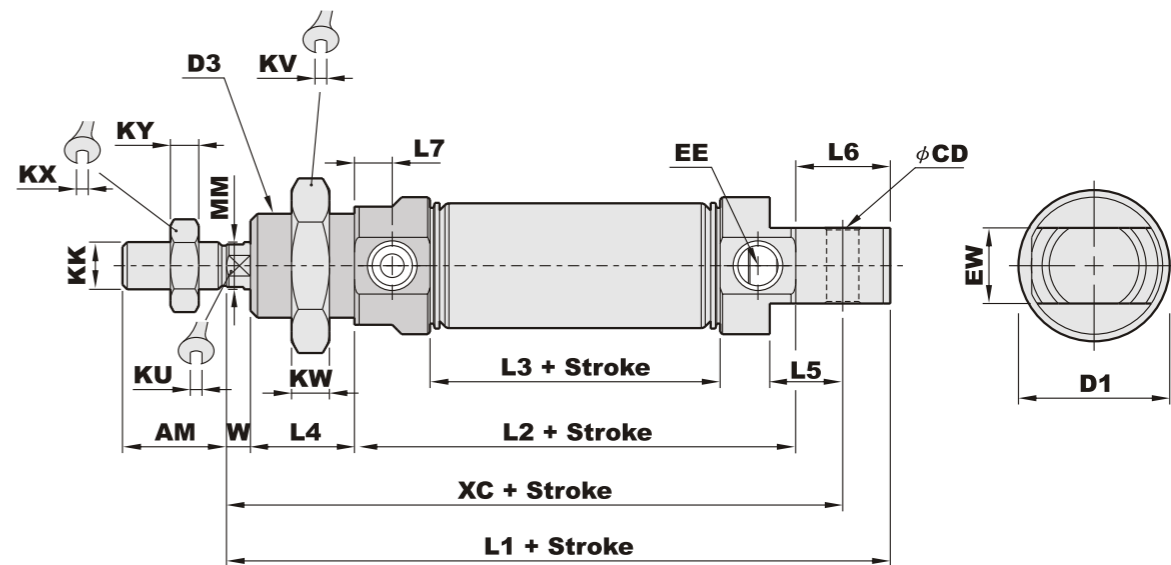

(Unit : mm)

Bore size	AM	D1	φ CD	D3	L1	L2	L3	L4	L5	L6
φ 20	20	29	φ 8	M22xP1.5	134	92	61	18	12	18
φ 25	22	29	φ 8	M22xP1.5	142.5	94.5	62.5	20	12	20
φ 32	22	37	φ 10	M27xP2.0	158	108	72	20	13.5	22
φ 40	24	45	φ 10	M33xP2.0	163	110	74	20	13.5	22

Bore size	L7	KK	KU	KV	KW	KX	KY	MM	W	EW	XC	EE
φ 20	7.75	M8xP1.25	7	32	8	13	6	φ 8	6	16	120	PS 1/8
φ 25	8	M10xP1.25	9	32	8	17	6	φ 10	8	16	129	PS 1/8
φ 32	9	M10xP1.25	10	35	9.5	17	6	φ 12	8	22	145	PS 1/8
φ 40	9	M12xP1.25	14	41	9.5	22	8	φ 16	11	26	150	PS 1/8

Dimensions

APDC Single acting/Spring extended/Boss-cut

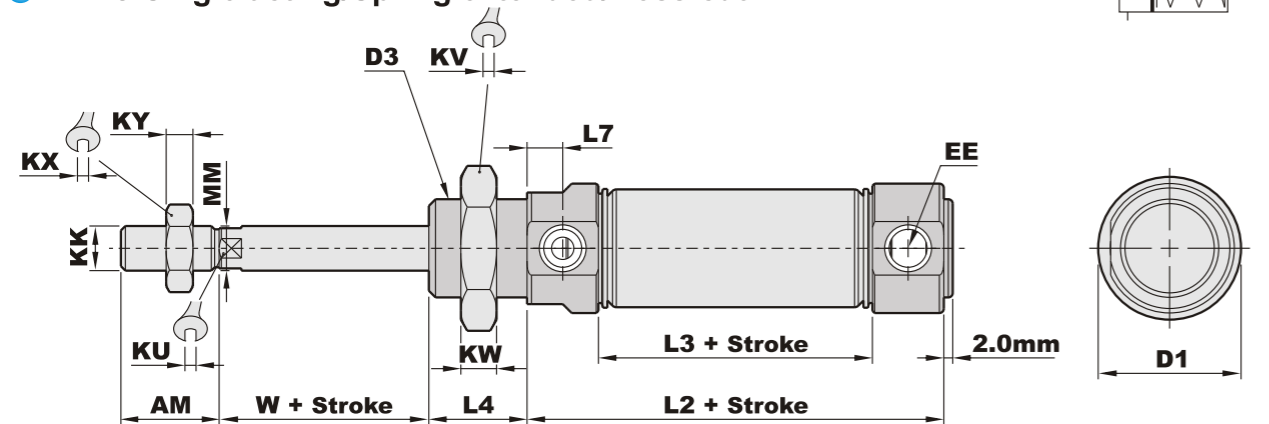

APD Single acting/Spring extended/Standard integrated clevis

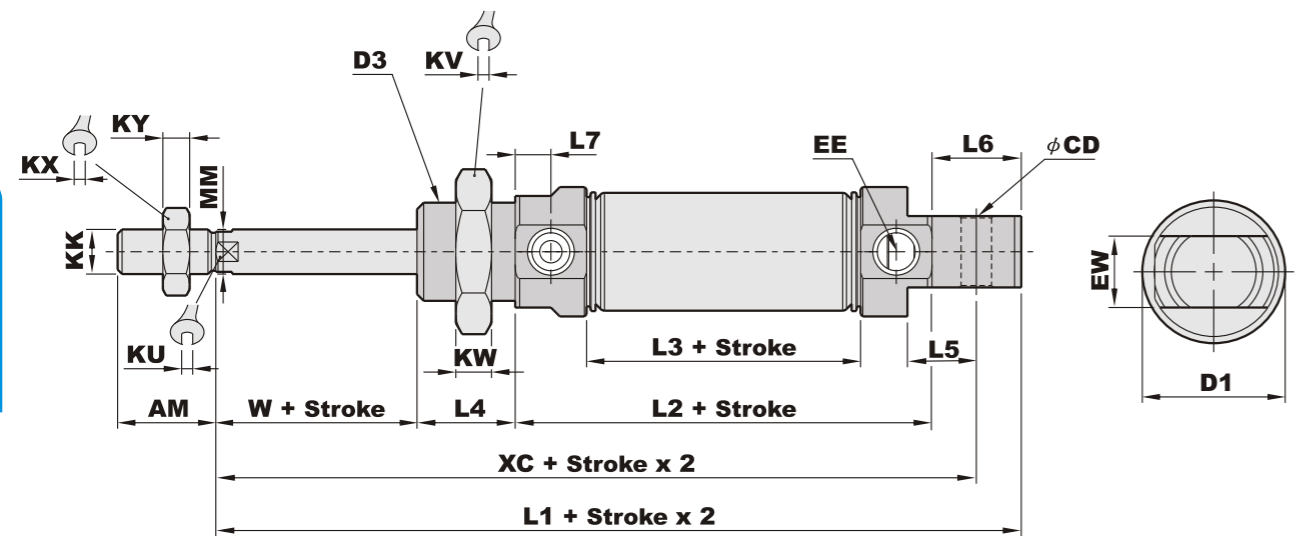

(Unit : mm)

Bore size	AM	D1	φ CD	D3	L1	L2	L3	L4	L5	L6
φ 20	20	29	φ 8	M22xP1.5	134	92	61	18	12	18
φ 25	22	29	φ 8	M22xP1.5	142.5	94.5	62.5	20	12	20
φ 32	22	37	φ 10	M27xP2.0	158	108	72	20	13.5	22
φ 40	24	45	φ 10	M33xP2.0	163	110	74	20	13.5	22

Bore size	L7	KK	KU	KV	KW	KX	KY	MM	W	EW	XC	EE
φ 20	7.75	M8xP1.25	7	32	8	13	6	φ 8	6	16	120	PS 1/8
φ 25	8	M10xP1.25	9	32	8	17	6	φ 10	8	16	129	PS 1/8
φ 32	9	M10xP1.25	10	35	9.5	17	6	φ 12	8	22	145	PS 1/8
φ 40	9	M12xP1.25	14	41	9.5	22	8	φ 16	11	26	150	PS 1/8

Dimensions

PCH Hollow double rod type

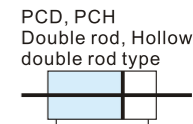
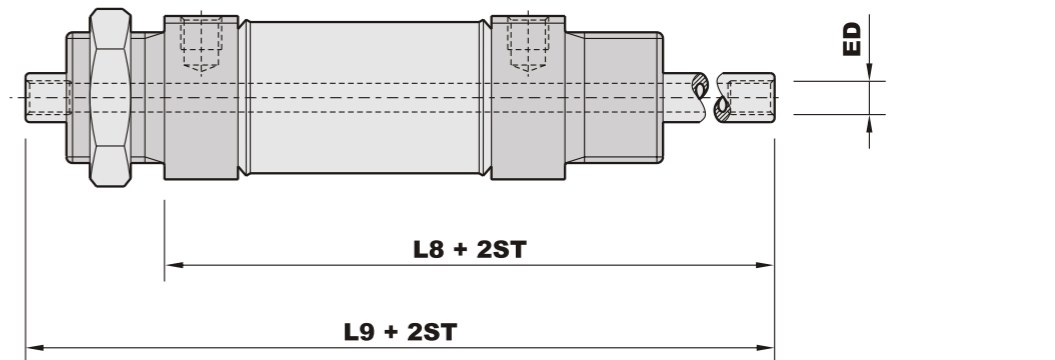

(Unit : mm)

Bore size	L8	L9	ED
φ 25	98	126	M5xP0.8x20
φ 32	112	140	PT1/8
φ 40	116	147	PT1/8

- Suitable for vacuum pad.
- Vacuum pad and other devices could be directly screwed on to rod end.
- Permanent magnetic is built-in.

Please refer to page 5-23 PC standard integrated clevis type for other dimensions.

PCM Dual stroke/Double rod

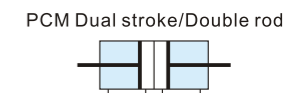
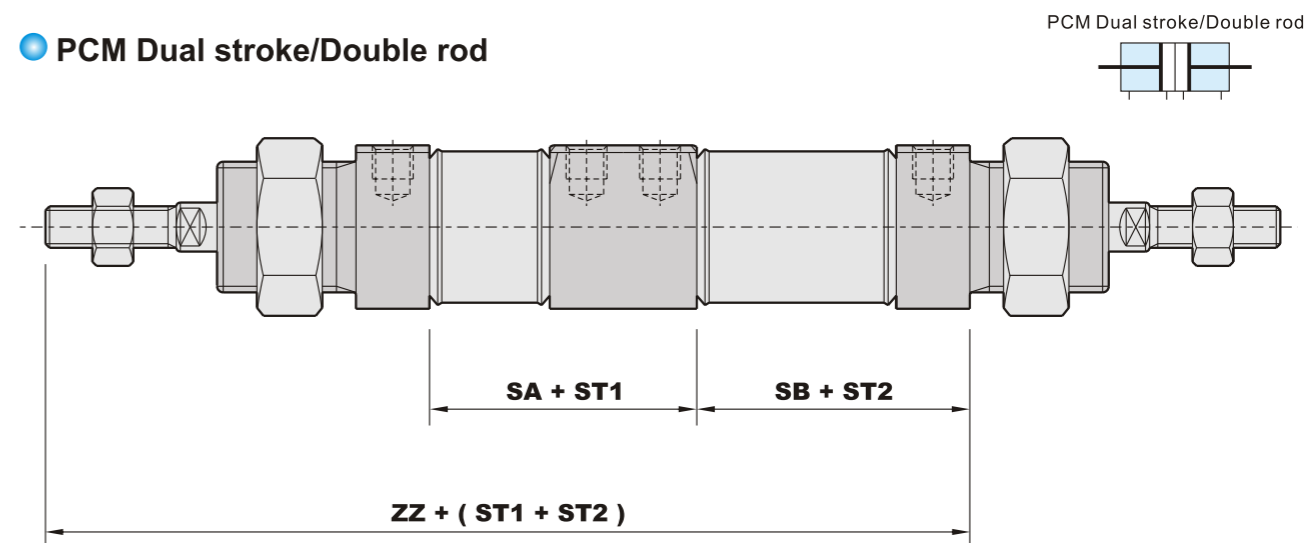

(Unit : mm)

Bore size	SA	SB	ZZ
φ 25	85.5	53.5	239
φ 32	101.5	65.5	267
φ 40	103	67	280

- Two cylinders are constructed as one cylinder in a shrinking back configuration.
- Cylinder stroke could be controlled in three or four steps.
- One end of piston rod is fixed, the cylinder barrel executes the movement, the cylinder must connected with flexible line connections.
- Applicable to positioning transportation, quantitative filling, right and left displacement, capable flow control...etc, which is for accuracy and speedy purpose.

Please refer to page 5-23 PC standard integrated clevis type for other dimensions.

Dimensions

PCG Dual stroke/Single rod/Boss-cut

PCG, PCF
Dual stroke/Single rod/Boss-cut
Dual stroke/Single rod/Standard
integrated clevis

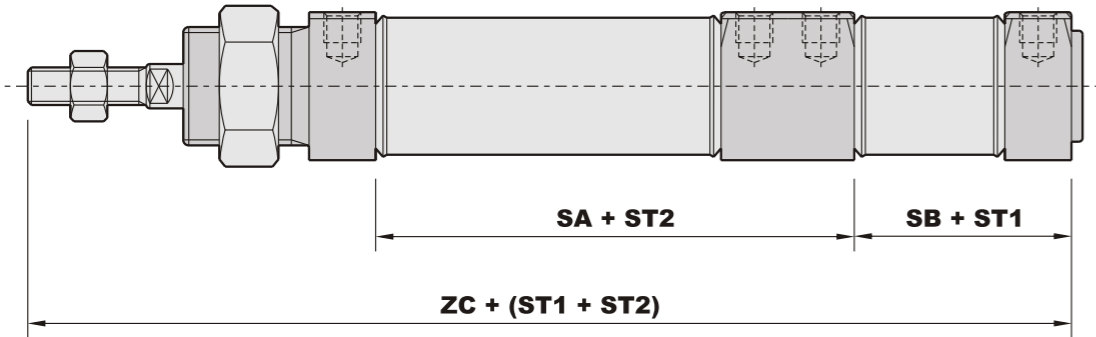

PCF Dual stroke/Single rod/Standard integrated clevis

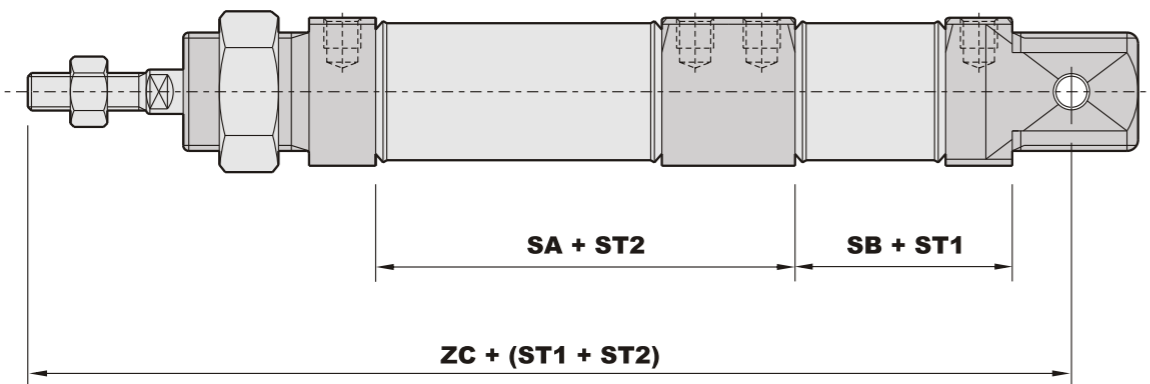

(Unit : mm)

Bore size	SA	SB	ZC	ZT
φ 32	101.5	65.5	225.5	217
φ 40	103	67	234	225

Please refer to page 5-23 PC standard integrated clevis type for other dimensions.

- The cylinder constructed as one cylinder in line allows double the output force.
- Cylinder stroke could be controlled in three steps.
- Applicable to position transportation, quantitative filling and flow control, right and left displacement.
- Adjustable cushions on both ends.
- Permanent magnet is built-in.

Dimension of mounting parts

Flange mounting(FA, FB)

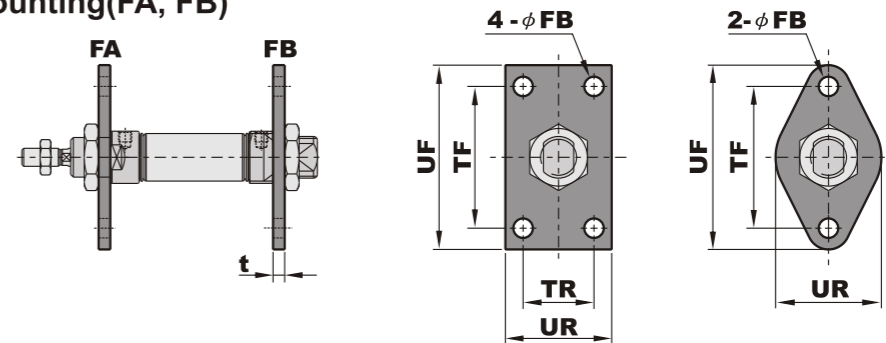

(φ 32, φ 40) (φ 12 ~ φ 25) (Unit : mm)

Bore size	TF	TR	UF	UR	I	φ FB	Bore size	TF	TR	UF	UR	I	φ FB
φ 12	40	--	52	30	3	φ 5.5	φ 25	50	--	66	40	3	φ 6.5
φ 16	40	--	52	30	3	φ 5.5	φ 32	50	26	64	40	3	φ 7
φ 20	50	--	66	40	3	φ 6.5	φ 40	54	30	74	50	4	φ 7

CB Integrated clevis mounting

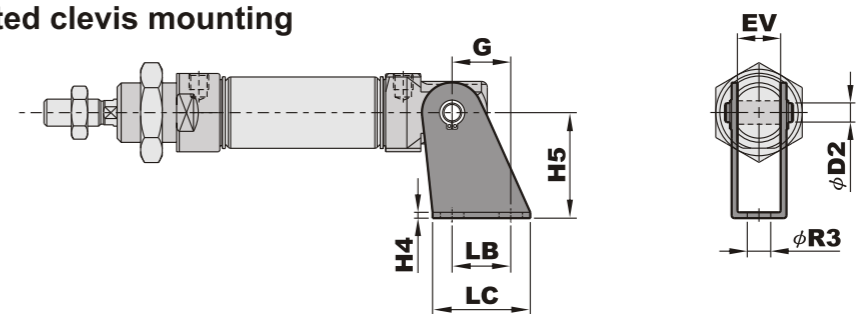

(Unit : mm)

Bore size	LB	LC	EV	H4	H5	G	φ D2	φ R3	Bore size	LB	LC	EV	H4	H5	G	φ D2	φ R3
φ 12	15	25	12	3	27	15	φ 6	φ 6	φ 25	20	32	16	3	30	18.5	φ 8	φ 7
φ 16	15	25	12	3	27	15	φ 6	φ 6	φ 32	25	40	22	3	40	22.5	φ 10	φ 9
φ 20	20	32	16	3	30	18.5	φ 8	φ 7	φ 40	25	40	26	3	40	22.5	φ 10	φ 9

LB Axial foot mounting

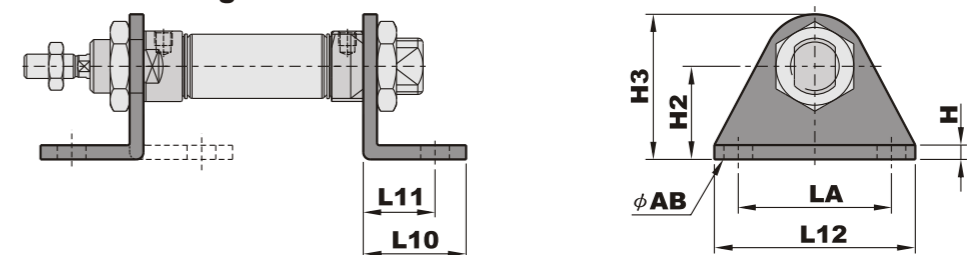

(Unit : mm)

Bore size	L10	L11	L12	LA	H	H2	H3	φ AB	Bore size	L10	L11	L12	LA	H	H2	H3	φ AB
φ 12	20.5	14	42	32	3	20	33	φ 6	φ 25	26	17	54	40	3	25	45	φ 7
φ 16	20.5	14	42	32	3	20	33	φ 6	φ 32	25	18	64	50	3.5	28	48	φ 7
φ 20	26	17	54	40	3	25	45	φ 7	φ 40	30	20	74	54	4	31.5	60	φ 7